

Basic Smart Inverter

9K
E09EM
12K
E12EM



33p Jet Cool
34p 2 Way Swing
34p Fast Heating
48p Dual Protection Filter
50p Auto Cleaning
54p Comfort Air
60p Quick & Easy Installation
64p Optional Wi-Fi Ready

Unit				9K	12K
Model Indoor Unit				USNW096W4A1	USNW126H4A1
Model Outdoor Unit				USUW096W4A1	USUW126H4A1
Indoor Unit					
Capacity	Cooling	Min/Rated/Max	W	890/2500/3700	900/3500/4040
	Heating +7°C	Min/Rated/Max	W	890/3200/4100	890/3800/5100
	Heating -7°C	Rated	W	3000	3600
Power Input	Cooling	Rated	W	730	1,120
	Heating +7°C	Rated	W	950	1,040
		Rated	W	3.42	3.13
EER				5.7	5.8
S.E.E.R.				2.5	3.5
P design C			kW	3.37	3.65
COP				3.8	3.8
S.C.O.P.				2.3	3.2
P design H			kW	A+	A+
Energy Label	Cooling			A	A
	Heating			154	211
Annual Energy Consumption	Cooling		kWh	847	1400
	Heating		kWh	20/25/33/39	20/25/33/39
Sound Pressure	Cooling	S/L/M/H	dBA	28/33/39	28/33/39
	Heating	L/M/H	dBA	58	58
Sound Power	Cooling	High	dBA	3.0 / 4.5 / 6.0 / 7.5	3.5 / 5.5 / 8.0 / 10.0
	Heating	S/L/M/H	m³/min	9.0	12.0
Air Flow Rate	Cooling	Max (Power)	m³/min	5.0 / 6.0 / 8.0	6.5 / 8.0 / 10.0
	Heating	L/M/H	m³/min	0.83	1.3
Dehumidification Rate			l/h	3.2 / 6.5	4.9 / 6.5
Running Current	Cooling	Rated/Max	A	4.2 / 6.0	4.6 / 6.0
	Heating	Rated/Max	A	3.2	4.9
Starting Current	Cooling	Rated	A	4.2	4.6
	Heating	Rated	A	1 / 220-240 / 50	1 / 220-240 / 50
Power Supply			∅ / V / Hz	15	15
Circuit Breaker			A	3 x 1.0	3 x 1.0
Power Supply Cable			N x mm²	4 x 0.75 (Including Earth)	4 x 0.75 (Including Earth)
Power & Transmission Cable			N x mm²	756*265*184	798*292*214
Dimension			mm	7.4	8.5
Net Weight			kg	30	30
Fan Motor Output			W		
Outdoor Unit					
Operation Range	Cooling	Min~Max	°CDB	-10~48	-10~48
	Heating	Min~Max	°CDB	-10~24	-10~24
Sound Pressure	Cooling	High	dBA	49	49
	Heating	High	dBA	49	49
Sound Power	Cooling	High	dBA	65	65
	Heating	High	dBA	27	27
Air Flow Rate	Length (Odu/Idu)	Min	m	3	3
		Max	m	15	15
		Max	m	7	7
Piping Connection	Liquid	OD(Outside)	mm	6.35	6.35
			inch	(1/4)	(1/4)
			mm	9.52	9.52
	Gas	OD(Outside)	mm	(3/8)	(3/8)
			inch	21.5	21.5
			inch	0.85	0.85
Refrigerant	Type			R410A	R410A
	Charge at 5.0m		g	920	970
	Additional charge		g/m	20	20
Fan Motor Output			W	43	43
Compressor Type				Rotary	Rotary
Net Weight			kg	28	28
Dimension			mm	717*483*230	717*483*230

* Specification, design and feature are subject to change without prior notice.

USNW096W4A1

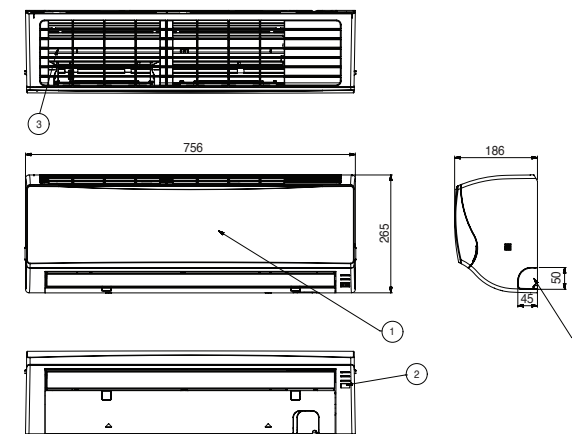

USNW126H4A1

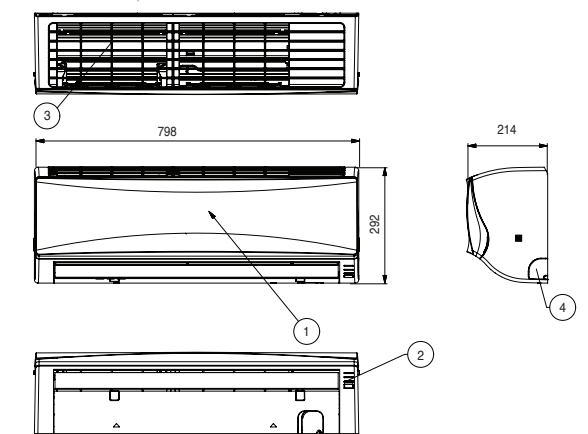

USUW096W4A1 / USUW126H4A1

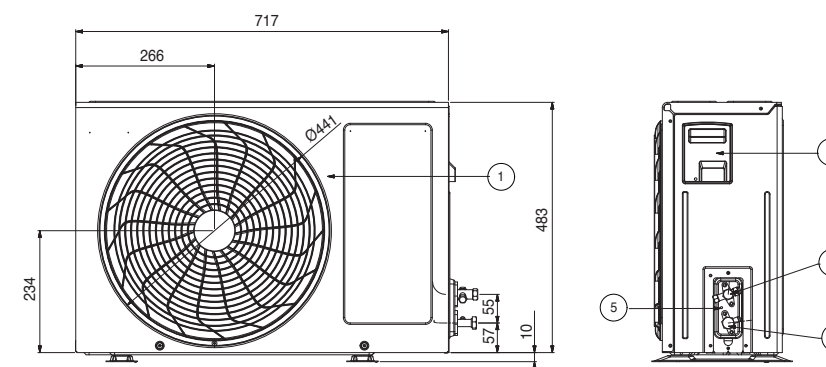
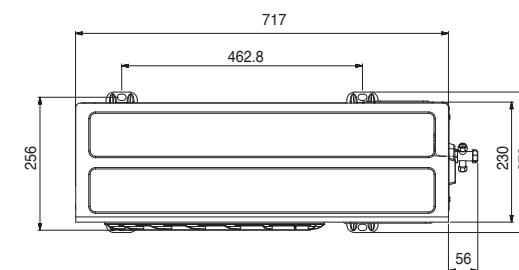

(Unit : mm)

Item No.	Part Name
1	Air Discharge Grille
2	Gas Pipe Connection Port
3	Liquid Pipe Connection Port
4	Power & Transmission connection
5	Earth Screw

* This product contains Fluorinated greenhouse gases (R410A).